



HYDROSTATIC ULTRASONIC COREHOLDER

# HUUC SERIES

*Rock-mechanics testing system for ultrasonic and permeability studies of porous media.*



**P · S1 · S2**

ULTRASONIC WAVES

**70 MPa**

CONFINING PRESSURE

**120 °C**

OPERATING  
TEMPERATURE

# OVERVIEW & TEST PROCEDURE

*From core loading to ultrasonic and permeability measurement*

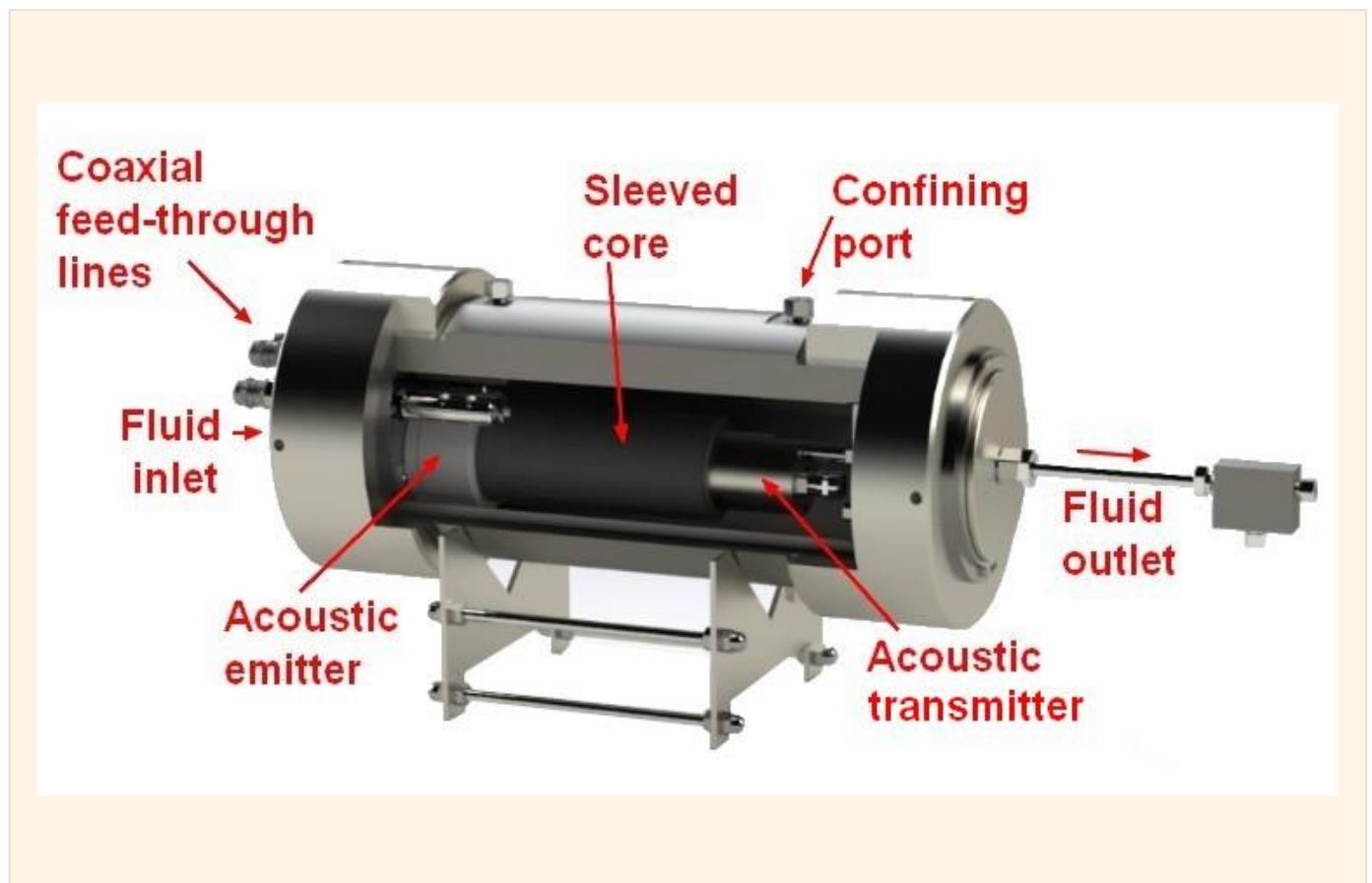

## 1

### CORE LOADING

Cylindrical sample placed in a Viton sleeve between a fixed acoustic emitter and a floating acoustic receiver. Confining fluid is introduced via the external pump.

## 2

### ULTRASONIC VELOCITY

The pulser excites a piezoelectric transducer; P, S1 and S2 waves propagate through the sample and are recorded by the receiving transducer for velocity calculation.

## 3

### PERMEABILITY

Pore fluid is injected at constant flow rate through the core. The pressure drop across the sample is monitored and permeability calculated by Darcy's law.

# CELL DESIGN & SPECIFICATIONS

*Internal architecture and standard configuration of the HUC Series*

## INTERNAL ARCHITECTURE

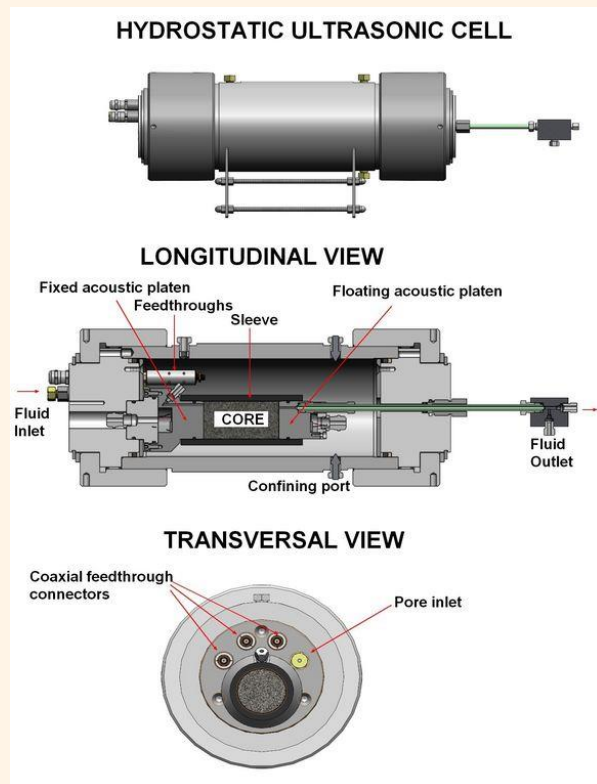

## TECHNICAL SPECIFICATIONS

Confining pressure	<b>70 MPa (10,000 psi)</b>
Temperature range	<b>Ambient → 120 °C</b>
Acoustic waves	<b>P · S1 · S2</b>
Frequency	<b>1 MHz</b>
Specimen diameter	<b>1.5 in (1 in optional)</b>
Specimen length	<b>3 in (other on request)</b>
Wetted parts	<b>Stainless steel (Hastelloy)</b>
Pore inlet / outlet	<b>1 / 1</b>
Port fittings	<b>1/8 inch</b>
Hydraulic fluid	<b>Silicone oil</b>

## WHAT YOU MEASURE

- ◆ Compressional ( $V_p$ ) and shear ( $V_{s1}$ ,  $V_{s2}$ ) wave velocities
- ◆ Dynamic elastic constants — Young's, bulk, shear, Poisson
- ◆ Rock permeability via Darcy's method
- ◆ Anisotropy assessment from S1 / S2 separation

## KEY FEATURES

- ◆ True hydrostatic confining (equal radial & axial)
- ◆ Stainless steel build · Hastelloy option
- ◆ Floxlab proprietary acquisition software
- ◆ Integrated P, S1 and S2 acoustic sensors
- ◆ Coaxial feedthroughs for in-vessel signals
- ◆ Accommodates a variety of core sizes



# GET IN TOUCH

*Discover how the HUC Series can support your laboratory.*



## ADDRESS

**23 rue du Port**

92000 Nanterre · France



## EMAIL

**contact@floxlab.com**



## PHONE

**+33 (0)1 81 93 12 85**

## SCAN ME



*Visit our website*

**www.floxlab.com**

Scan the QR code with your phone camera to access our full product catalogue and request a quote.